



# FORZA

---

Ranger

***Technical Sheet***  
*Model N1530P15*



# FORZA

Ranger

Industrial CNC laser cutting machine for plates.

**CUTTING / MARKING / PUNCHING**

The FORZA Ranger laser cutter is the latest generation of our line of sheet metal machinery with all the improvements requested by our customers from previous models.

Greater cutting speed, acceleration and robustness.  
It is capable of working with full **5ftx10ft(1525mmx3050mm)** boards up to **1/2in (13mm)**.

## Specific features

FEATURE	DETAIL
Application	Cutting of plates
Nominal working area	1500mm x 3000mm   4.9ft x 9.8ft
Total space for worktop	1525mm x 3050mm   5ft x 10ft
Nominal laser power	1500W
Nominal cut thickness in ASTM A36(1)	10mm   3/8in
Maximum limit cutting thickness in ASTM A36(2)	13mm   1/2in
Maximum acceleration	1.0G   32.0ft/s <sup>2</sup>
Maximum XY translation speed	100 m/min   5.5 ft/s
Cutting precision(3)	± 0.1mm

1. It is the limit with which a clean, burr-free cut can be obtained; up to this thickness it can be cut permanently.
2. It is not recommended to size the machine with this power if you intend to work permanently with thicknesses greater than the nominal one, as the cut will begin to present more pronounced lines and possible burrs as it moves away from the nominal thickness. In addition, the piercing may be unstable at maximum thicknesses, so it must be carefully controlled by the operator.
3. The cutting accuracy is taken from a 0.7mm stainless steel plate, it considers the repeatability and accuracy of the machine. 0.1mm accuracy means that when cutting a 100.0mm plate it can measure 100.1mm or 99.9mm. If the thickness of the material increases the error may be greater due to the nature of the materials and the width of the cut.



## Special Features

### Smart Focus Technology



Automatic head for working on uneven surfaces, no matter if the plate is warped, the head will maintain a constant distance throughout the cut.

### Marking Technology



Not only can it cut, it also has a marking function, ideal for engraving lines for post-bending processing or engraving numbers and letters.

### Gravity Cut



You can save up to 60% of the time in circular rectangular pattern cuts and taking advantage of the inertia of the movement.

### FORZA Play software.



Spanish-language software specialized for cutting, user-friendly, with anti-collision alarm system and maintenance notices

### Find edge system.

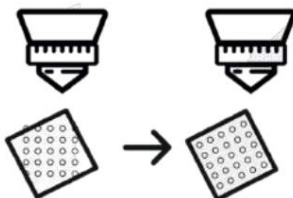

Detects edges to position drawings on contours and take advantage of the material, which can reduce waste by up to 40%.

### Automatic gas control



The machine automatically exchanges and selects the gas it needs to cut depending on the material, whether it is oxygen or nitrogen.

## General Specifications

SPECIFICATION	DETAIL
<b>Model</b>	<b>FORZA Ranger – N1530P15</b>
Laser Type/Laser Technology	Fiber Laser 1064nm ± 30nm
Laser diameter in the QBH	20um
Nominal power of Fiber laser	1500W
Fiber laser working power range	5 to 100% (±0.5%)
Stability at output power	± 1.5W
Laser working frequency	4 to 5000Hz
Source protection level	IP54
Source model for use	MFSC-1500W Max Photonics
Types of work	CUTTING / OUTLINED / PERFORATED
Focusing system	SMART FOCUS TECHNOLOGY (1) —
Type of gas to use for cutting	O2, N2 or Air
Proportional oxygen regulation	Analog control 10 bar Airtac
Head model	OSPRI - LC40
Focus range	-10mm ~ +10mm
Maximum focusing speed	100mm/s
Protection system	Prevention and detection of impacts
Creating pre-loaded cutting profiles	Yes (2)
Laser cutting width	0.1mm ~ 1.5mm(3) —

1. The focusing system incorporates an internal servomotor that moves the lens and in addition to a capacitive sensor that maintains the distance between the head and the plate during cutting.
2. The parameters are available on the library.forzalaser.com platform and the customer can download them for free and a local backup is left on the machine for quick access.
3. The width of the cut is directly proportional to the thickness of the material; the greater the thickness, the greater the width of the cut. The type of filler gas also has an impact; with oxygen the cut line is wider.

Cutting precision	Depending on the thickness(4)_
Cutting angle	<2° (5)
Repeatability	±0.05mm
Accuracy of movement	±0.02mm
Nominal working area	1500mm x 3000mm   4.9ft x 9.8ft
Total space for worktop unit	1525mm x 3050mm   5ft x 10ft
Maximum displacement in Z	80 mm   3.15in
Maximum cutting speed	30 m/min   1.64 ft/s
Maximum travel speed	100 m/min   5.5ft/s
Maximum XY acceleration	1.0G   32.0ft/s <sup>2</sup>
XY motion system	Rack / Pinion
Z motion system	Screwball
XYZ servo motor power	X: 750W
	Yx2: 850W
	Z: 400W
Servo motor brand	Innovance
Lubrication system	Automatic by working path
Wireless Control	Wifi remote control
Extraction system	Extraction by external motor
Maximum load on plate	450kg <sup>6)</sup>

4. Cutting accuracy is 0.1mm for thicknesses up to 0.7mm. If the cutting thickness increases, the accuracy is affected by the cutting width up to 0.5mm for ½ inch sheets.
5. The angle of inclination depends on the thickness of the cutting material and also the type of gas being used, the greater the thickness the angle of inclination can be affected, oxygen can increase the angle of inclination of the cut.
6. The maximum weight corresponds to a complete 5ftx10ft plate of 1/2in ASTM A36 steel, this weight must be distributed throughout the plate.

Maximum consumption of the laser source	5 500W
Maximum chiller consumption	2 700W
Maximum consumption of the extractor hood	1 500W
Maximum consumption of movement and control	5 000W
Peak power consumption	14 700W
Average energy consumption	8 820W <sup>7)</sup>
Working voltage	Single phase: 220V (50-60Hz) Three-phase: 220V/380V/440V (50-60Hz)
Maximum current per line	74A @ 220VAC 1ph   43A @ 220VAC 3ph
	25A @ 380VAC 3ph
	22A @ 440VAC 3ph
Maximum current for cable dimension(8)	93A @ 220VAC 1ph   54A @ 220VAC 3ph
	31A @ 380VAC 3ph
	28A @ 440VAC 3ph
Required wire gauge of breaker box	2 x 4AWG @220V 1ph   3 x 8AWG @220V 3ph
	3 x 10AWG @ 380VAC 3ph
	3 x 12AWG @ 440VAC 3ph
	+1 x 10AWG Ground
Recommended breaker for the machine	80A @ 220VAC 1ph   50A @ 220VAC 3ph
	30A @ 380VAC 3ph
	25 A @ 440VAC 3ph

7. Average consumption is calculated from 60% of peak consumption, not all components are on during operation, the on/off interactions of systems such as the chiller and the power supply cause this index to drop. For an hourly electrical consumption calculation please use the average consumption.

8. The maximum line current is calculated with the maximum consumption current and a safety factor of 1.25. It is used for the sizing of electrical wiring.

Power cable length	10 m   32.8ft
Pneumatic supply required for rotor	6bar
Type of communication	RJ45, WIFI, USB 3.0
Supported design formats	AI, DXF, PLT, LXD, G
Software for use	FORZA PLAY
Software Language	Spanish and English
PC control interface	By screen and by manual control
Cooling method	Dissipated by water
Chiller tank size	13L
Gas connection diameter	8mm O2 and 8mm N2 hose (Nylon)
Maximum pressure allowed in the head	25bar
Maximum air/N2 inlet pressure	20bar
Maximum O2 inlet pressure	10bar
Recommended N2 inlet pressure	16bar
Recommended O2 intake pressure	6bar(9)
Equipment weight	1590kg
Weight of equipment for transport	1670kg
Team measurements	4360 x 2860 x 1800mm   14.3x9.4x6.9ft
Transport measures	4800 x 3200 x 2200mm   15.8x10.5x7.2ft
Resistance on the work floor	6.5 Kg/cm <sup>2</sup>
Relative humidity	< 85%
Working temperature	2 – 35o C
Storage temperature	8 – 30o C
Certifications	CE, RoHS

9. This pressure is used at the tank pressure gauge output, and the valves are calibrated from this pressure.



## Machine measurements

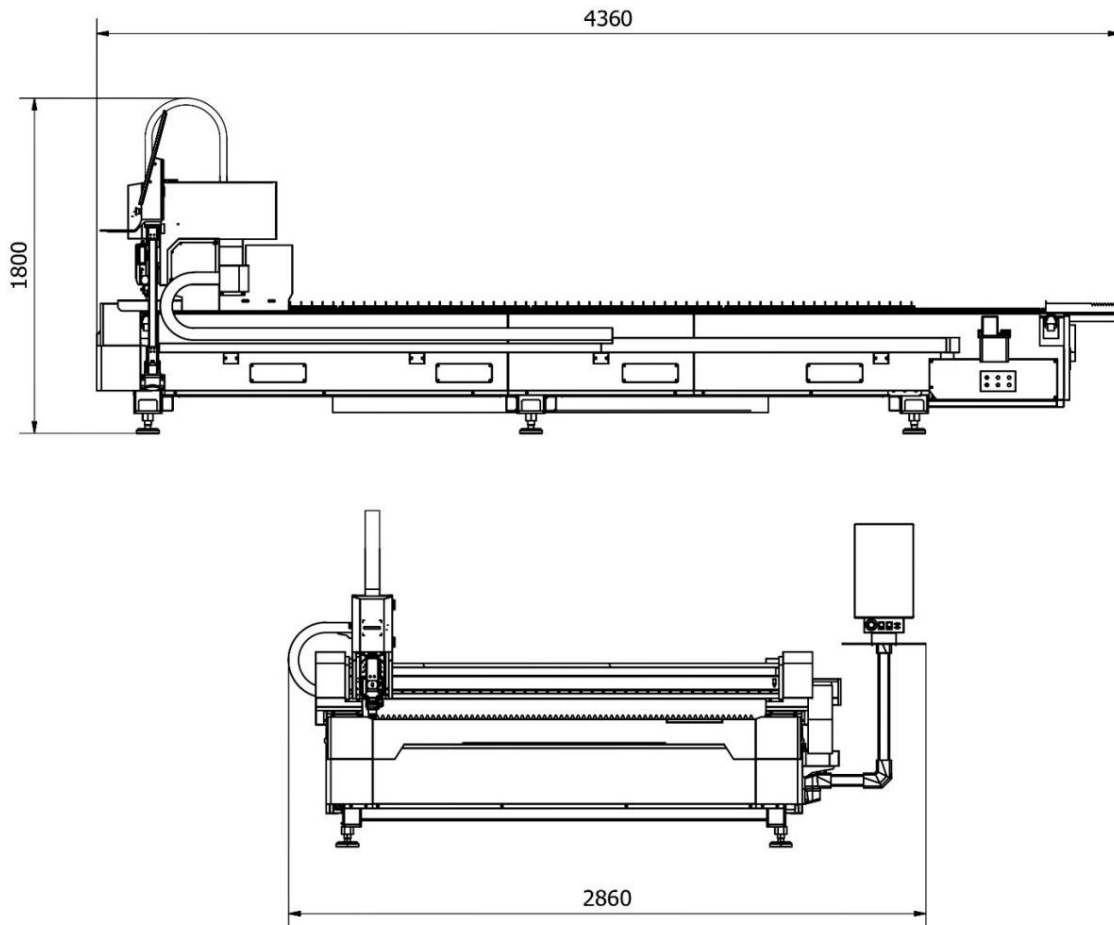

## Space required

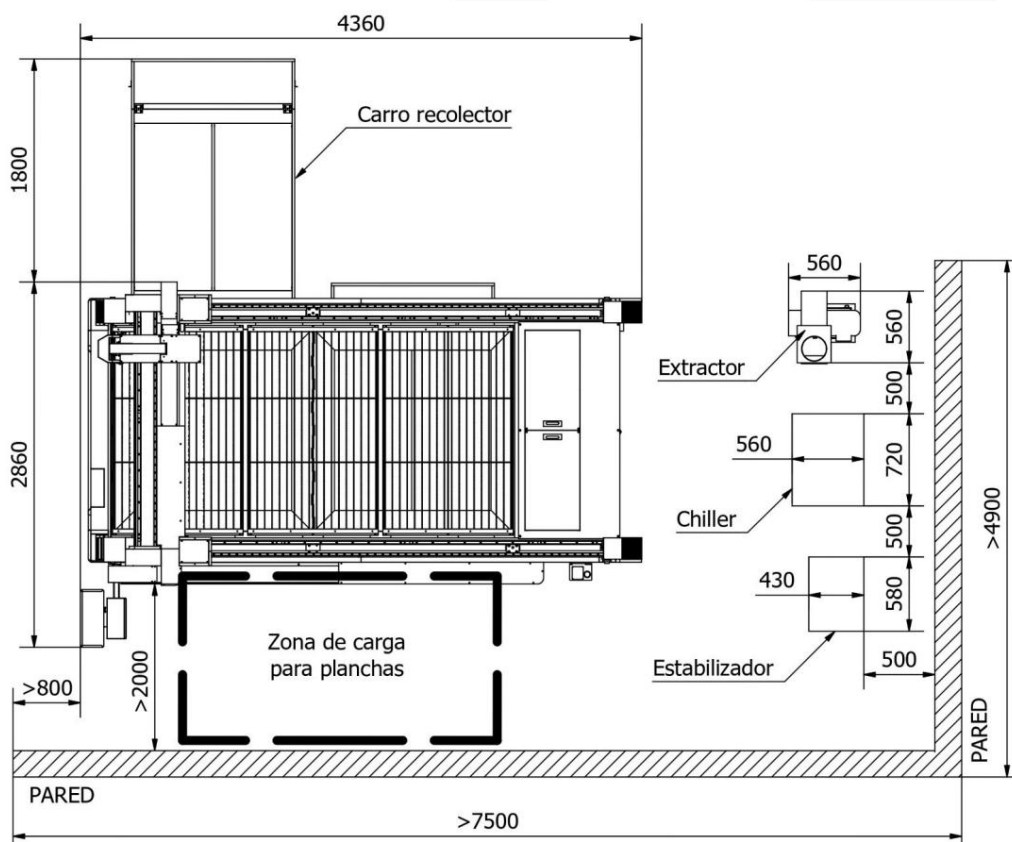

## Applicable materials





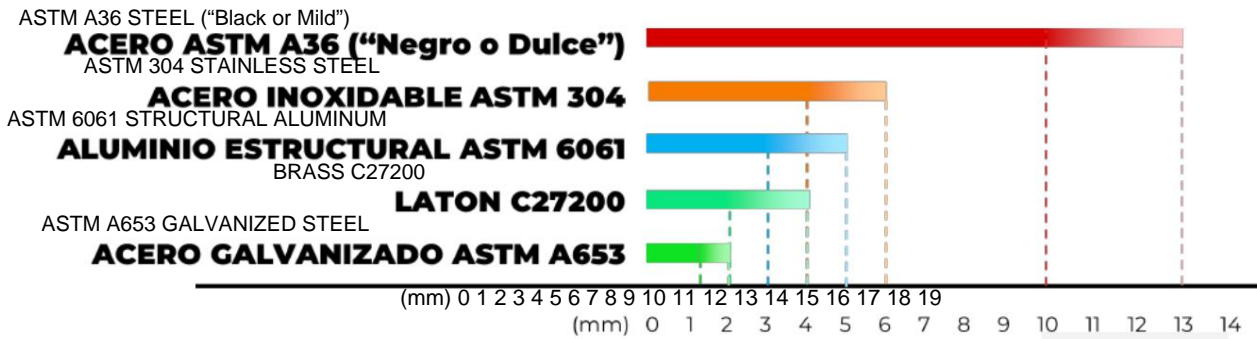









## Cutting thicknesses by material















MATERIAL	Ideal thickness 1	Maximum thickness <sup>2</sup>
ASTM A36 STEEL ("Black or Mild")	10mm   3/8in	13mm   1/2in
ASTM 304 STAINLESS STEEL	4mm   5/32in	6mm   1/4in
ASTM 6061 STRUCTURAL ALUMINIUM	3mm   1/8in	5mm   13/64in
BRASS C27200	2mm   5/64in	4mm   5/32in
ASTM A653 GALVANIZED STEEL	1.25mm   3/64in	2mm   5/64in

1. The ideal thickness refers to the thickness that is cut with a completely clean edge and no burrs.
2. The maximum thickness is the limit that can be cut. From the ideal thickness, lines appear as the thickness increases. It is not recommended to size the machine to the maximum thickness. Cutting at limit thicknesses also restricts the geometries that can be cut due to the temperature of the material.

## Packing List:

- 1 x FORZA RANGER 1500W machine.(1) 
- 1 x LC40 Head. 
- 1 x Wireless remote control. \*\* 
- 1 x MFSC Power Supply - 1500W Max Photonics 
- 1 x Wireless Keyboard and Mouse. 
- 1 x Laser Protective Glasses with Case. 
- 2 x Waste collection cart 
- 6 x Machine leveling feet 
- 1 x Screen support structure kit (2 pieces). 1 
- x Gutter and track assembly kit (4 pieces). 
- 49 x Support Swords 
- 1 x Monitor screen 
- 1 x Industrial CPU 



### -POWER CABLES and DUCT-

- 1 x Monitor Power Cable. 
- 10 mx Metal gutter. 
- 2 x PU hoses for CH cooling, 10mx8mm. 
- 2 x PU hoses for CF cooling, 10mx19mm. 
- 1xVoltage regulator for display. 
- 5m x Cable 2x4 AWG + 1x10AWG, BE (T:Eye-Tip) @220v1ph 
- 5m x Cable 3x8 AWG + 1x10AWG, BT (T:Eye-Tip)@220v3ph 
- 5m x Cable 3x12 AWG + 1x10AWG, BT (T:Eye-Tip) @440v3ph 
- 5m x Cable 3x10 AWG + 1x10AWG, BE (T:Eye-Tip) @380v3ph 
- 2m x Cable 4x10 AWG + 1x10 AWG, TE (T:Eye-Eye)@220/440v3ph 
- 10m x Cable 3x4 AWG + 1x10 AWG, EM (T:Eye-Tip) @1ph 
- 10m x Cable 4x10 AWG + 1x10 AWG, EM (T:Eye-Tip) @3ph 
- 15m x Cable 4x12 AWG, MX (T:Eye-Tip) 





### -LICENSES-

- 1xFORZA Play Software License
- 1xFORZA Vectors 1 year license
- 1xFORZA Academy Full License 1 year
- 1xSuper 7 SUPPORT License 4 years old

















### -PERIPHERALS-

- 1 x Voltage stabilizer 220V-1ph / 30 KVA. @1ph - (2) 
- 1 x Voltage stabilizer 380V-3ph / 30 KVA.@3ph - (2) 
- 1 x Automatic chiller 1.5kW (Chiller).(3) 
- 1 x Industrial fume extractor 1.5 kW. 
- 1 x Transformer [220V - 380V] 30KVA @220v3ph. (4) 
- 1 x Transformer [220V - 380V] 30KVA @440v3ph. (4) 

### -CONSUMABLES-

- 1xTop protection lens. 
- 9xLower protection lenses. 
- 16x Cutting nozzles of various sizes 
- 1xCapacitive sensor ceramic base. 
- 1xLiter ISO 68 Oil. 

### -TOOL BOX-







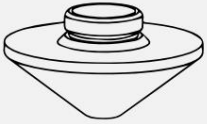

- 1 x Plastic tool box. 
- 1 x Scotch tape. 
- 1 x Masking Tape. 
- 1 x Metric allen key set. 
- 1 x 4pcs Screwdriver Set. 
- 1 x Set of door and switch keys. 
- 1 x Parrot or parakeet beak key. 
- 1 x Cotton swabs and cleaners. 
- 1 x Bag of bolts and dowels 6mm 
- 1 x Branding poster 
- 1 x WiFi module 
- 1 x Set of electrical terminals 
- 1 x Set of service terminals 
- 10 x 3/8" expansion bolts 
- 30 x Screws + Fischer plug 
- 1 x QBH Protector 
- 2 x 10" Extraction Tube Clamps 

T: Transformer, B: Breaker, E: Stabilizer, M: Machine, F: Laser Source, C: Chiller, H: Head, X: Extractor, G: Ground

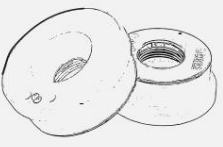
The cables are sized without the power factor. The safety factor is only requested for the customer's connection.

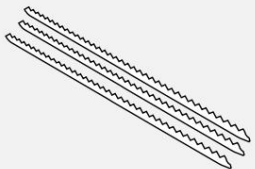
Item	Measures	Net Weight	Gross Weight
 (1)	W: 4800mm H: 2200mm L:3200mm	1690kg	2500kg
 (2)	W: 500mm H: 1000mm L:800mm	168kg	168kg
 (3)	W: 715mm H: 950mm L:610mm	102kg	102kg
 (4)	W: 400mm H: 400mm L:200mm	138kg	138kg

## Consumables:

Photo	Article	Model	Measures	Life time
	Cutting nozzle: single/double	xxxx	D:28mm M11x0.75 H:15mm	200 hours
	Lower protective lens	CF-L30.0X5.0-4K	D:30mm T:5mm	200 hours
	Distilled water	xxxx	13 liters	2 months
	Ceramic sensor base capacitive	CF-BCD28M11L12	D(e):28mm	1000 hours
			D(i):24.5mm	
			M11x0.75	
			H:12mm	
	ISOVG68 lubricating oil	xxxx	1 liter	50,000 meters
	Plate Support Swords	xxxx	L:1600mm T:2mm	300,000 meters
	Blue grease for pine nuts	xxxx	Lithium grease	10,000 meters
	Second lower lens of protection	CF-L30.0X5.0-4K	D:30mm T:5mm	not specified
	Superior protection lens	CF-L21.5X2.0-4K	D:21.5mm T:2mm	not specified

Manufactured Parts:



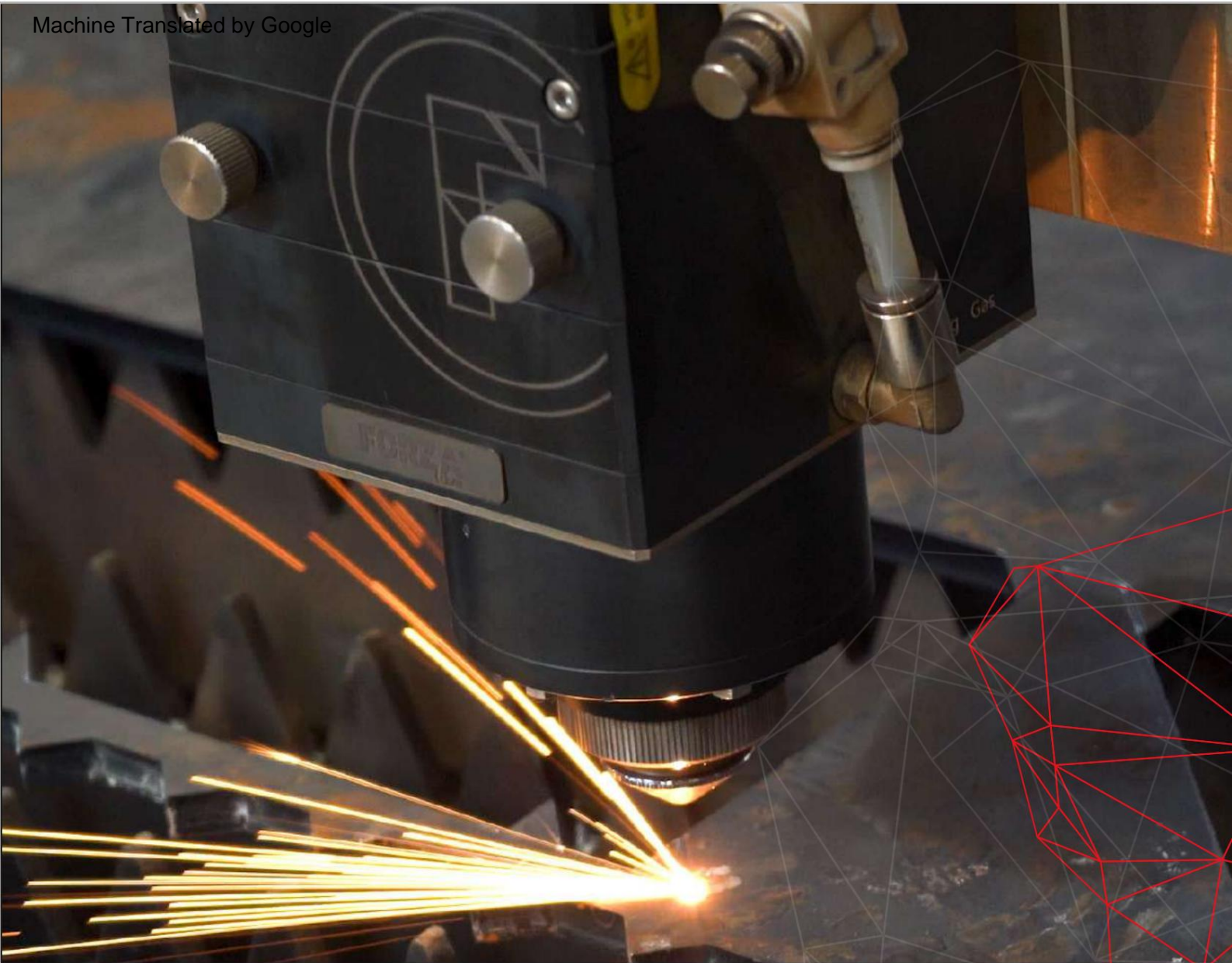

With Forza Laser laser specialists, our team has everything you need to grow your own business to the maximum.

Visit our social networks



[www.forzaser.com](http://www.forzaser.com)